

DESCRIZIONE

La serie K100R è una valvola di riduzione autoazionata a singola sede, con bilanciamento della pressione a valle mediante soffietto in acciaio inox. E' una costruzione robusta a bassa manutenzione. Progettate per mantenere una pressione di valle costante, le valvole Serie K100R possono essere utilizzate con i più comuni fluidi di processo quali acqua, acqua surriscaldata, vapore saturo, olio diatermico, gas non pericolosi e tutti gli altri fluidi purchè compatibili con i materiali impiegati.

DESCRIPTION

The K100R series is a pressure reducing valve self actuated, single seat, with bellows balancing system in st. steel. It is a rugged construction to assure a low maintenance. Designed to maintain a constant downstream pressure, the K100R series is suitable for the most common process fluids such as water, superheated water, steam, diathermic oil, air, No dangerous gases and other noncorrosive fluids.



CARATTERISTICHE

MASSIMA PRESSIONE DI INGRESSO	40 BAR con liquidi 25 BAR con vapore e gas
TENUTA VERSO L'ESTERNO	Soffietto in X2CrNiMo1810
AMPIO CAMPO DI SET POINT	Da 0,1 a 16 BARG

FEATURES

MAX INLET PRESSURE	40 bar with liquids 25 bar with steam and gases
LEAKAGE TIGHTNESS	Bellows in X2CrNiMo1810
WIDE RANGE OF SET POINT	From 0,1 BARG to 16 BARG

OPZIONI DISPONIBILI SU RICHIESTA

CV/KV PASSAGGIO RIDOTTO
Sede & otturatore EN10088 X2CrNiMo1810 (AISI316)
Altri materiali corpo su richiesta

OPTIONS ON REQUEST

REDUCED CV/KV
Trim in EN10088 X2CrNiMo1810 (AISI316)
Other Body Materials available on request

DATI TECNICI

DIAMETRI NOMINALI	da DN15 a DN100 Std
	Altri DN su richiesta
ATTACCHI CORPO	flangiati UNI EN 1092 PN16 - PN40
Corpo Valvola (PN16/PN25): Ghisa sferoidale EN-GJS-400-18 (EN-JS1025) verniciatura epossidica	Cappello: Acciaio al carbonio C40
	Interni: EN10088 X2CrNiMo1810
Corpo Valvola (PN16/PN40): Acciaio al Carbonio GP240GHN (1.0619)	Cappello: Acciaio al carbonio C40
	Interni: EN10088 X2CrNiMo1810
Corpo Valvola (PN16/PN40): Acciaio INOX GX5CrNiMo (1.4408)	Cappello: EN10088 X2CrNiMo1810
	Interni: EN10088 X2CrNiMo1810

TECHNICAL DATA

BODY SIZES	from DN15 to DN100 Std
	Other DN On Request
BODY CONNECTIONS	flanged UNI EN 1092 PN16 - PN40
Valve Body (PN16/PN25): Spheroidal cast iron EN-GJS-400-18 (EN-JS1025) painted	Bonnet: C40 carbon steel
	Trim: EN10088 X2CrNiMo1810
Valve Body (PN16/PN40) : Carbon steel GP240GHN (1.0619)	Bonnet: C40 carbon steel
	Trim: EN10088 X2CrNiMo1810
Valve Body (PN16/PN40): Stainless steel GX5CrNiMo (1.4408)	Bonnet: EN10088 X2CrNiMo1810
	Trim: EN10088 X2CrNiMo1810

SEDE E OTTURATORE

TENUTA	Tenuta metallica - Classe V°
	Tenuta elastica - Classe VI°
PROFILO OTTURATORE	Apertura Rapida
PASSAGGIO	Integrale

SEAT AND PLUG

SEAL	Tightness Class V°
	Tightness Class VI°
PLUG TYPES	Quick Opening
PORT	Full Port

TENUTA STELO

STANDARD	Soffietto in X2CrNiMo1810
----------	---------------------------

PACKING

STANDARD	Bellows in X2CrNiMo1810
----------	-------------------------

ATTUATORE

TIPO ATTUATORE	molla / membrana autoazionato
MASSIMA PRESSIONE REGOLABILE	16 BARG
TEMPERATURA AMBIENTE	-20...+70°C
MATERIALE CASSA	Acciaio al Carbonio 1.1191 Verniciatura Epossidica
MATERIALE MEMBRANA	EPDM
CASTELLO A COLONNE	Acciaio al Carbonio Zincato (IEC 534)
CONNESSIONI	1/4"NPT-F

ACTUATOR

TYPE	Spring / diaphragm type - self-actuated
MAX SET PRESSURE	16 BARG
AMBIENT TEMPERATURE	-20...+70°C
ACTUATOR CASTING MATERIAL	Carbon Steel 1.1191 anti corrosive painted
DIAPHRAGM MATERIAL	EPDM
YOKE MATERIAL	Zinc plated carbon steel (IEC 534)
CONNECTIONS	1/4"NPT-F

COEFFICIENTE DI PORTATA

FLOW RATE COEFFICIENTS

	DIAMETRO NOMINALE - SIZES								
	DN 15	DN 20	DN 25	DN 32	DN 40	DN 50	DN 65	DN 80	DN 100
Cv	4,05	5,78	10,4	15,6	25,4	37	65,9	94,8	132,9
Kv	3,5	5	9	13,5	22	32	57	82	115

(Cv= portata in GPM con 1 psi di pressione differenziale)
(Kv= portata in m³/h con 1 bar di pressione differenziale)

(Cv= flowrate in USGPM with 1 psi of differential Pressure)
(Kv= flowrate in m³/h with 1 bar of differential Pressure)

PRESSIONI DI TARATURA IN BARG IN FUNZIONE DEGLI ATTUATORI DISPONIBILI

SET PRESSURES IN BARG REFERRING TO AVAILABLE ACTUATORS

SET PRESSURES RANGE RANGE DI TARATURA	DIAMETRI NOMINALI - SIZES								
	DN 15	DN 20	DN 25	DN 32	DN 40	DN 50	DN 65	DN 80	DN 100
0,1 - 1,5 Barg	295	295	295	295	295	295	295	295	295
1,0 - 3,0 Barg	255	255	255	255	255	255	295	295	295
2,0 - 5,0 Barg	230	230	230	230	230	230	255	255	255
4,0 - 8,0 Barg	195	195	195	195	195	195	230	230	230
7,0 - 16 Barg	175	175	175	175	175	175	195	195	195

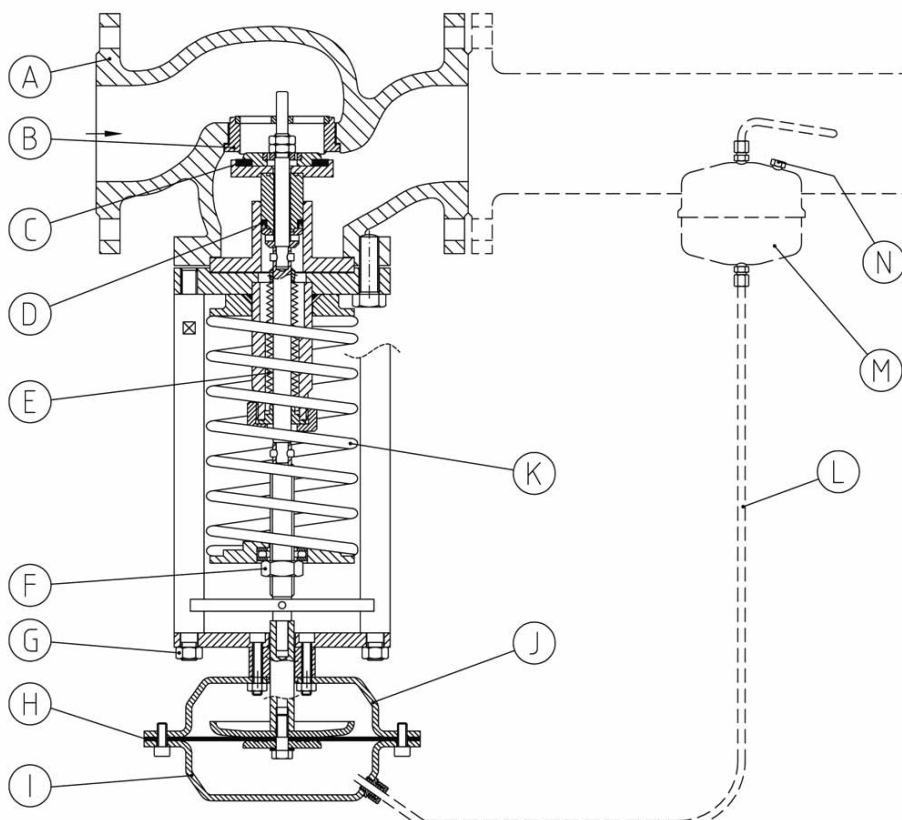

- A – Body valve
- B – Seat (replaceable)
- C – Seal
- D – Compensation gasket
- E – Bellows
- F – Adjusting nut
- G – Nut
- H – Diaphragm
- I – Actuator casing (Upper)
- J – Actuator casing (Lower)
- K – Springs
- L – Impulse pipe
- M – Tank
- N – Coupling

Valve Size	GENERAL DIMENSIONS & WEIGHTS			
DN	A (mm)	B (mm)	L (mm max)	Appr. Weight (Kgs)
DN 15	130	48	440	20
DN 20	150	53	445	22
DN 25	160	58	450	24
DN 32	180	70	455	28
DN 40	200	75	463	32
DN 50	230	83	475	35
DN 65	290	93	560	52
DN 80	310	100	560	57
DN 100	350	110	575	68

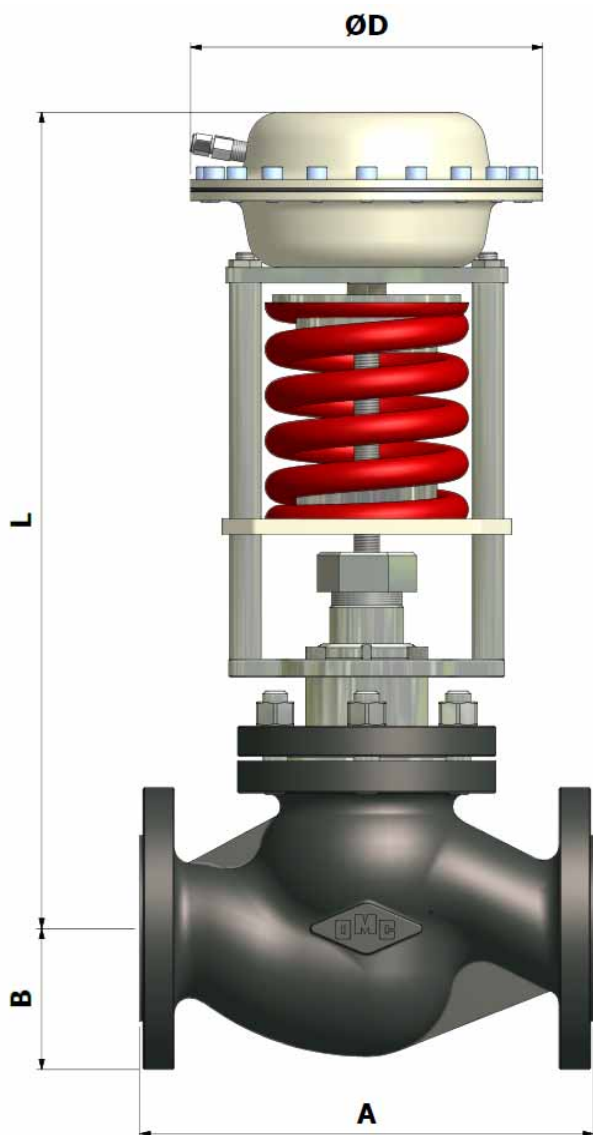

SERVOMOTORE - ACTUATOR	
TIPO TYPE	Ø D (mm)
AV 175	175
AV 195	195
AV 230	230
AV 255	255
AV 295	295

